

TORSIONALLY RIGID AND FLEXIBLE

BELLOWS COUPLINGS

SERIES	BK		2	–	10,000 Nm
	BX		10,000	–	100,000 Nm



R+W[®]
COUPLING TECHNOLOGY

THE ULTIMATE COUPLING FROM 2 – 100,000 Nm

www.rwcouplings.com

Optional:



TORSIONALLY STIFF METAL BELLOWS COUPLINGS

Areas of application:

Highly dynamic axes of:

- Servo drives
- CNC machinery
- Robotics
- Material handling systems
- Linear actuators
- Automation equipment
- Sheet metal processing equipment
- Printing machinery
- Packaging machinery
- Woodworking machinery
- Textile machinery
- Metal cutting machinery
- Stone cutting machinery
- Gear grinding machinery

Features:

- compact
- zero backlash
- high torsional stiffness
- exact transmission of angular motion and torque
- infinite life
- wear and maintenance free
- high operational dependability
- various mounting options
- easy mounting and dismounting
- compensation for axial, lateral, and angular shaft misalignment with smooth, quiet operation
- low restoring forces
- balanced for high speeds

MODELS

FEATURES

APPLICATION EXAMPLES

BK 1

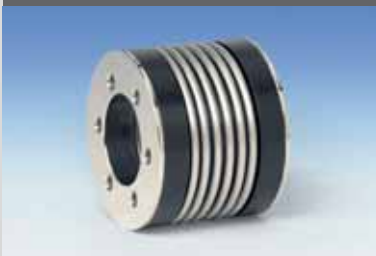

**with flange mounting
from 15-10,000 Nm**

- special design applications
- available with custom or standard flanges

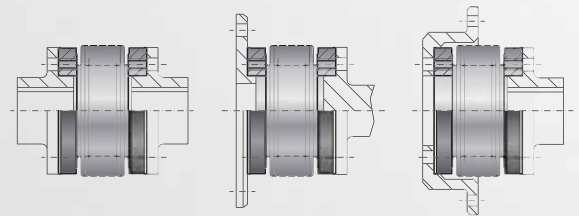

see page 5

BK 2



**with clamping hubs
from 15-10,000 Nm**

- easy to mount
- multiple lengths available
- low moment of inertia
- finely balanced up to 40,000 rpm available

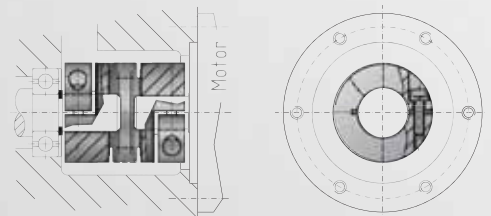

see page 6

BKH



**with fully split hubs
from 15-1,500 Nm**

- for lateral mounting
- multiple lengths available
- low moment of inertia
- suited for pre-aligned shafts

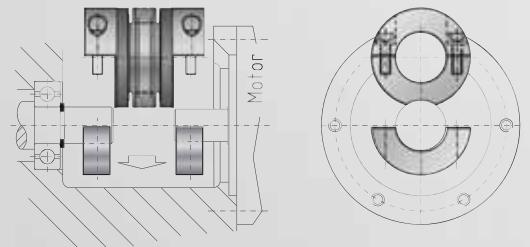

see page 7

BKL



**with clamping hubs (economy class)
from 2-500 Nm**

- low cost version
- self opening clamp system optional
- low moment of inertia

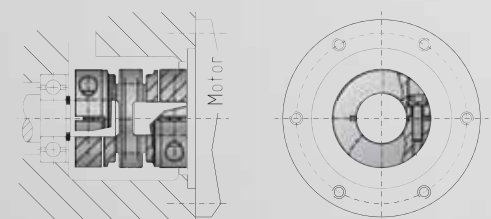

see page 8

Optional:



MODELS

FEATURES

APPLICATION EXAMPLES

BKC



**with clamping hubs (compact version)
from 15-500 Nm**

- low moment of inertia
- compact design
- self opening clamp system optional

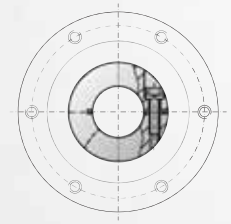
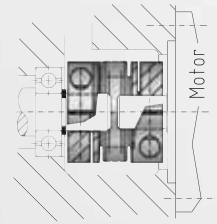

see page 9

BKM



**with clamping hubs
from 20-1,000 Nm**

- increased torque capacity with small outside diameter
- easy to mount
- lowest moment of inertia

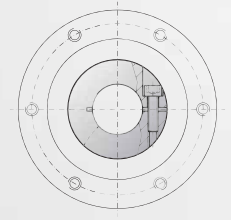
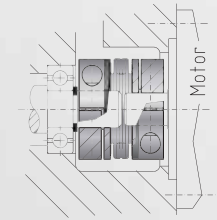

see page 10

BKS



**with clamping hubs
from 15-500 Nm**

- all stainless steel construction
- temperatures up to 300° C
- easy to mount

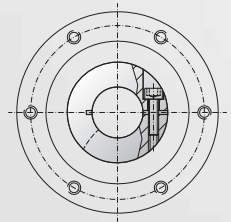
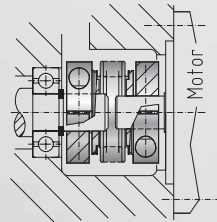

see page 11

BK 3



**with tapered conical sleeves
from 15-10,000 Nm**

- high clamping force
- rugged, high torque design
- new jack screw design suited for space restricted applications

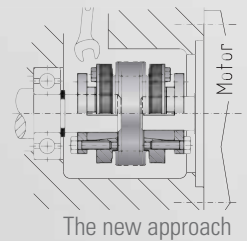
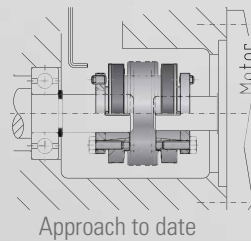

see page 12

BK 5



**with tapered press fit connection
from 15-1,500 Nm**

- absolutely backlash free
- easy mounting and dismounting
- wear free, press fit connection
- electrically and thermally isolating

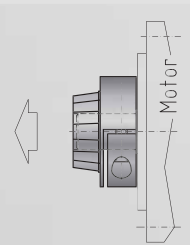
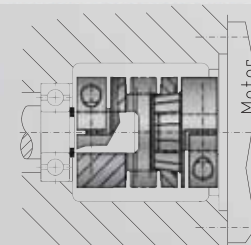

see page 13

Optional:



TORSIONALLY STIFF METAL BELLOWS COUPLINGS

MODELS

FEATURES

APPLICATION EXAMPLES

BK 6



with clamping ring and tapered press fit connection from 15-1,500 Nm

- for axial mounting
- absolutely backlash free
- easy mounting and dismounting
- electrically and thermally isolating

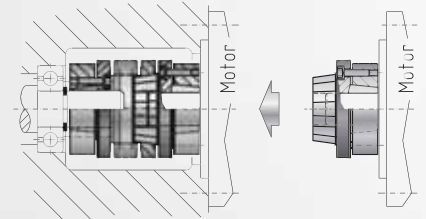

see page 14

BK 7



with expanding shaft from 15-300 Nm

- for easy hollow shaft mounting
- suited for space restricted installations
- adapts mismatched shaft and bore diameters

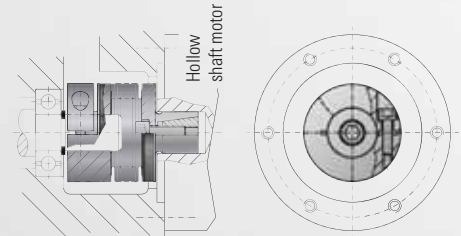

see page 15

BK 8



for ISO flange mounting from 15-2,600 Nm

- for ISO gearboxes or output flanges
- backlash free with high torsional rigidity
- high transmittable torques with compact design

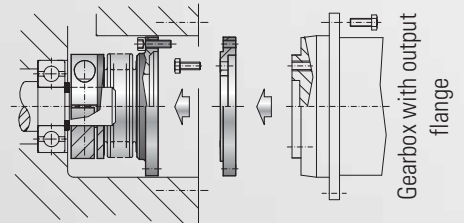

see page 16

BX Series



Bellows couplings for higher torque from 10-100 KNm

- robust construction
- maintenance free
- compact

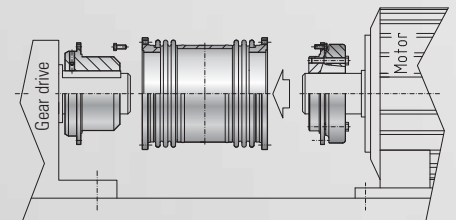

see page 17

ATEX



for use in explosive atmospheres

- available for the full product range
- for hazardous areas 1/21 and 2/22 bellows couplings are registered according to the directive ATEX 95a



see page 22

Optional:



STAINLESS STEEL

MODEL BK1

BACKLASH-FREE, TORSIONALLY STIFF METAL BELLOWS COUPLINGS

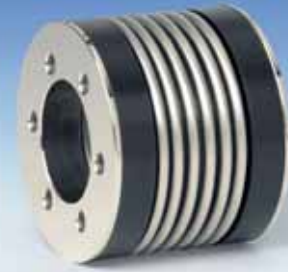

with flange mounting

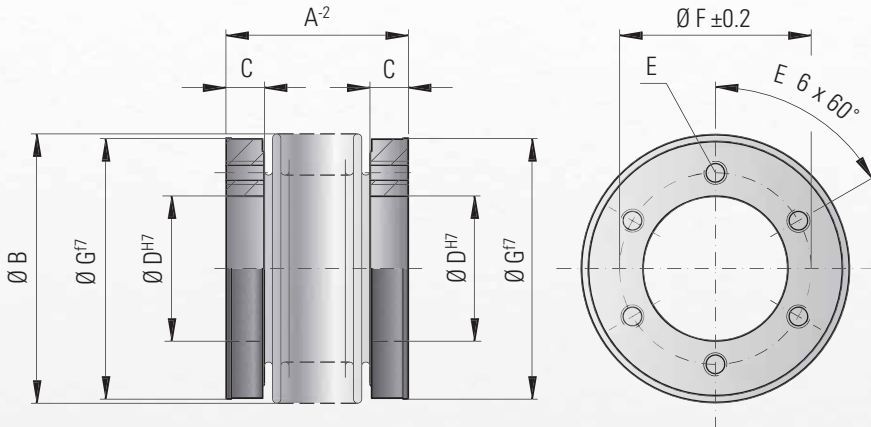

Features:

- special design applications
- available with custom or standard flanges

Material:

Bellows made from highly flexible, high grade stainless steel; flanges made from steel

Design:

The flanges have six threaded mounting holes and the ID and OD are concentrically machined to ISO H7/f7 tolerances; flanges with custom bore diameters, mounting threads, and bolt circles are available upon request.

Absolutely backlash free due to frictional connection

Temperature range:

-30 to +100° C (-22 to +212° F)

Speeds:

Up to 10,000 rpm; in excess of 10,000 rpm with finely balanced version (up to G = 2.5)

Service life:

Maintenance free with infinite life when operated within the technical specifications

Brief overloads:

Acceptable up to 1.5x the rated torque

Tolerance:

Recommend H7/f7

Non standard applications:

Custom designs with various tolerances, materials, bolt circles, dimensions, etc. available upon request

Ordering example

BK1/150/62/XX

Model
Series / Nm
Overall length mm
Non standard e.g. stainless steel

Model BK 1		Series																							
		15		30		60		150		200		300		500		800		1500		4000		6000		10000	
Rated torque (Nm)	T _{KN}	15		30		60		150		200		300		500		800		1500		4000		6000		10000	
Overall length (mm)	A ²	30	37	36	44	43	53	50	62	53	65	56	70	64	77	81	100	145	138	150					
Outside diameter of bellows (mm)	B	49		55		66		81		90		110		124		133		157		200		253		303	
Fit length/thread depth (mm)	C	7.5		10		11		13		14.5		15		16		18		22		30		30		36	
Inside diameter H7 (mm)	D	25		28		38		50		58		65		70		75		85		100		145		190	
Fastening threads	E	6 x M5		6 x M5		6 x M6		6 x M6		6 x M6		6 x M8		6 x M8		6 x M10		6 x M16		6 x M20		8 x M20		8 x M24	
Bolt circle diameter ± 0.2 (mm)	F	35		37		46		62		70		80		94		90		110		140		190		234	
Outside diameter f7 (mm)	G	49		55		66		81		90		110		122		116		140		182		235		295	
Moment of inertia (10 ³ kgm ²)	J _{total}	0.07	0.08	0.14	0.15	0.30	0.32	0.90	0.95	1.30	1.40	1.95	2.10	3.0	3.4	4.3	10.6	46	132	350					
Approximate weight (kg)		0.15		0.2		0.3		0.6		0.8		1.35		1.8		1.9		3.3		8.9		13.9		23.7	
Torsional stiffness (10 ³ Nm/rad)	C _T	20	15	39	28	76	55	175	110	191	140	450	350	510	500	780	1304	3400	5700	10950					
Axial ± (mm)	Max. values	1	2	1	2	1.5	2	2	3	2	3	2.5	3.5	2.5	3.5	3.5	3.5	3.5	3.5	3	3				
Lateral ± (mm)		0.15	0.2	0.2	0.25	0.2	0.25	0.2	0.25	0.25	0.3	0.25	0.3	0.3	0.35	0.35	0.35	0.35	0.35	0.4	0.4	0.4			
Angular ± (degree)		1	1.5	1	1.5	1	1.5	1	1.5	1	1.5	1	1.5	1	1.5	1.5	1.5	1.5	1.5	1.5	1.5	1.5			
Axial spring stiffness (N/mm)	C _a	25	15	50	30	72	48	82	52	90	60	105	71	70	48	100	320	565	1030	985					
Lateral spring stiffness (N/mm)	C _r	475	137	900	270	1200	420	1550	435	2040	610	3750	1050	2500	840	2000	3600	6070	19200	21800					

* 1 Nm = 8.85 in lbs

Optional:



STAINLESS STEEL

MODEL BK2

BACKLASH-FREE, TORSIONALLY STIFF METAL BELLOWS COUPLINGS



with clamping hubs

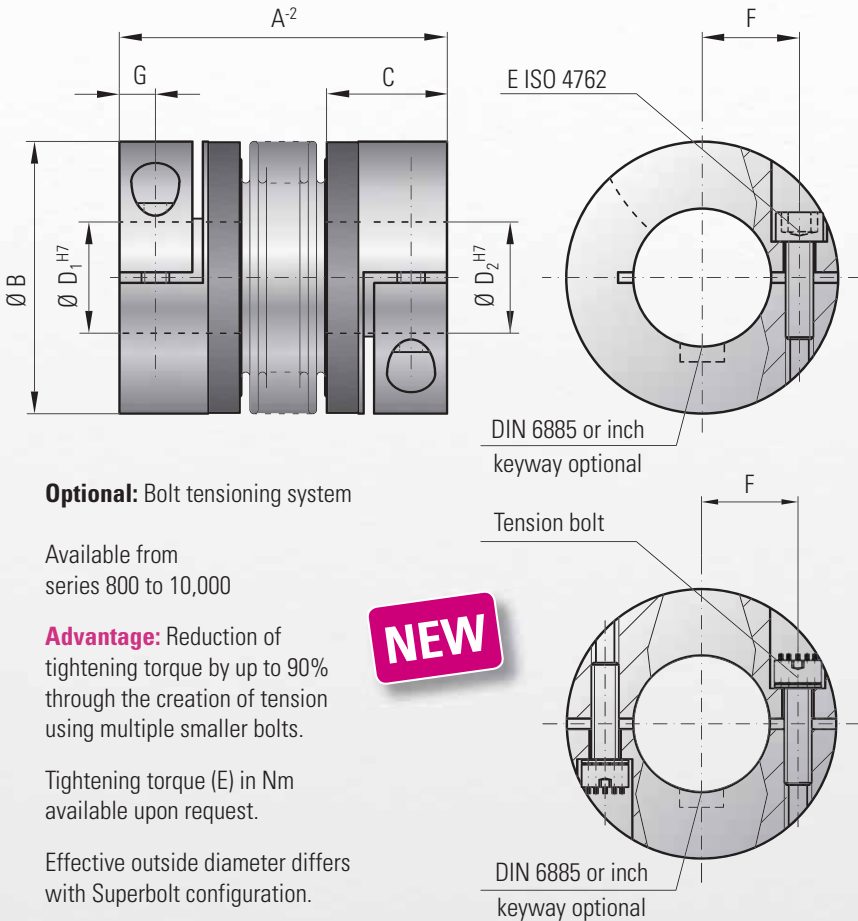

Optional: Bolt tensioning system

Available from series 800 to 10,000

Advantage: Reduction of tightening torque by up to 90% through the creation of tension using multiple smaller bolts.

Tightening torque (E) in Nm available upon request.

Effective outside diameter differs with Superbolt configuration.

NEW

Features:

- easy to mount
- multiple lengths available
- low moment of inertia

Material:

Bellows made from highly flexible, high grade stainless steel; see below for hub material

Design:

With a single ISO 4762 radial clamping screw per hub. Series 800 and up with two clamping screws 180 degrees opposed

Absolutely backlash free due to frictional clamp connection

Temperature range:

-30 to +100° C (-22 to +212° F)

Speeds:

Up to 10,000 rpm; in excess of 10,000 rpm with finely balanced version (up to G = 2.5)

Service life:

Maintenance free with infinite life when operated within the technical specifications

Brief overloads:

Acceptable up to 1.5x the rated torque

Fit tolerance:

Overall clearance between hub and shaft 0.01-0.05 mm

Non standard applications:

Custom designs with various tolerances, keyways, materials, dimensions, etc. available upon request

Model BK 2		Series																																						
		15			30			60			80			150			200			300			500			800			1500			4000			6000			10000		
Rated torque (Nm)	T_{KN}	15			30			60			80			150			200			300			500			800			1500			4000			6000			10000		
Overall length (mm)	A^{-2}	59	66	99	69	77	113	83	93	130	94	106	143	95	107	144	105	117	163	111	125	200	133	146	169	140	179	166	230	225	252	288								
Outside diameter (mm)	B	49			55			66			81			81			90			110			124			134			157			200			253			303		
Fit length (mm)	C	22			27			31			36			36			41			43			51			45			55			85			107			129		
Inside diameter possible from \emptyset to \emptyset H7 (mm)	D_1/D_2	8-28			10-30			12-35			14-42			19-42			22-45			24-60			35-60			40-75			50-80			50-90			60-140			70-180		
Fastening screw ISO 4762		M5			M6			M8			M10			M10			M12			M12			M16			2xM16			2xM20			2xM24			2xM24			2xM30		
Tightening torque of the fastening screw (Nm)	E	8			15			40			50			70			120			130			200			250			470			1200			1200			2400		
Distance between centerlines (mm)	F	17			19			23			27			27			31			39			41			2x48			2x55			65			90			117		
Distance (mm)	G	6.5			7.5			9.5			11			11			12.5			13			16.5			18			22.5			28			35			42		
Moment of inertia (10^{-3} kgm ²)	J_{ges}	0.06	0.07	0.08	0.12	0.13	0.14	0.32	0.35	0.4	0.8	0.85	0.9	1.9	2	2.1	3.2	3.4	3.6	7.6	7.9	8.3	14.3	14.6	14.8	16.2	17	43	45	165	495	1214								
Hub material		Al optional steel			Al optional steel			Al optional steel			Al optional steel			steel optional Al			steel optional Al			steel optional Al			steel optional Al			steel			steel			steel			steel			steel		
Approximate weight (kg)		0.16			0.26			0.48			0.8			1.85			2.65			4			6.3			5.7			11.5			28.8			49.4			80.9		
Torsional stiffness (10^9 Nm/rad)	C_T	20	15	14	39	28	27	76	55	54	129	85	84	175	110	97	191	140	135	450	350	340	510	500	400	780	711	1304	1180	3400	5700	10950								
Axial \pm (mm)	Max. values	1	2	3	1	2	3	1.5	2	3	2	3	4	2	3	4	2	3	4	2.5	3.5	4.5	2.5	3.5	4.5	3.5	4.5	3.5	4.5	3.5	4.5	3.5	4.5	3	3					
Lateral \pm (mm)		0.15	0.2	1	0.2	0.25	1	0.2	0.25	1	0.2	0.25	1	0.2	0.25	1	0.25	0.3	1	0.25	0.3	1	0.3	0.35	1	0.35	1	0.35	1	0.4	0.4	0.4	0.4							
Angular \pm (degree)		1	1.5	2	1	1.5	2	1	1.5	2	1	1.5	2	1	1.5	2	1	1.5	2	1	1.5	2	1	1.5	2	1.5	2	1.5	2	1.5	2	1.5	2	1.5	1.5					
Axial spring stiffness (N/mm)	C_a	25	15	84	50	30	118	72	48	165	48	32	144	82	52	130	90	60	280	105	71	605	70	48	85	100	285	320	440	565	1030	985								
Lateral spring stiffness (N/mm)	C_r	475	137	140	900	270	224	1200	420	337	920	290	401	1550	435	500	2040	610	750	3750	1050	1200	2500	840	614	2000	1490	3600	1700	6070	19200	21800								

* 1 Nm = 8.85 in lbs

Optional:



STAINLESS STEEL

MODEL BKH

BACKLASH-FREE, TORSIONALLY STIFF METAL BELLOWS COUPLINGS



with fully split hubs

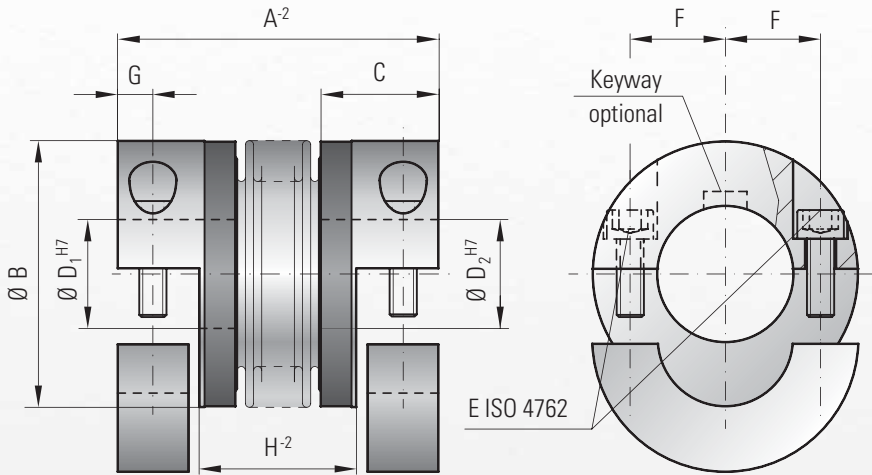

Features:

- for lateral mounting
- multiple lengths available
- low moment of inertia
- suited for pre-aligned shafts

Material:

Bellows made from highly flexible, high grade stainless steel; see below for hub material

Design:

Both clamping hubs are completely separable due to split hubs; each with two ISO 4762 radial clamping screws

Absolutely backlash free due to frictional clamp connection

Temperature range:

-30 to +100° C (-22 to +212° F)

Speeds:

Up to 10,000 rpm; in excess of 10,000 rpm with finely balanced version (up to G = 2.5)

Service life:

Maintenance free with infinite life when operated within the technical specifications

Brief overloads:

Acceptable up to 1.5x the rated torque

Fit tolerance:

Overall clearance between hub and shaft 0.01-0.05 mm

Non standard applications:

Custom designs with various tolerances, keyways, materials, dimensions, etc. available upon request

Ordering example

BKH / 80 / 94 / 20 / 22 / XX

- Model
- Series / Nm
- Overall length mm
- Bore Ø D1 H7
- Bore Ø D2 H7
- Non standard e.g. anodized

Model BKH		Series																			
		15		30		60		80		150		200		300		500		800		1500	
Rated torque (Nm)	T _{KN}	15		30		60		80		150		200		300		500		800		1500	
Overall length (mm)	A ⁻²	59	66	69	77	83	93	94	106	95	107	105	117	111	125	133	146	140	166		
Outside diameter (mm)	B	49		55		66		81		81		90		110		124		134		157	
Fit length (mm)	C	22		27		31		36		36		41		43		51		45		55	
Inside diameter possible from Ø to Ø H7 (mm)	D _{1/2}	8-28		10-30		12-32		14-42		19-42		22-45		24-60		35-60		40-75		50-80	
Fastening screw ISO 4762	E	M5		M6		M8		M10		M10		M12		M12		M16		M16		M20	
Tightening torque of the fastening screw (Nm)		8	15	40	50	70	120	130	200	250	470										
Distance between centerlines (mm)	F	17		19		23		27		27		31		39		41		48		55	
Distance (mm)	G	6.5		7.5		9.5		11		11		12.5		13		16.5		18		22.5	
Distance (mm)	H ⁻²	29	36	35	43	41	51	47	59	48	60	51	63	55	69	62	75	65.5	71		
Moment of inertia (10 ⁻³ kgm ²)	J _{total}	0.07	0.08	0.14	0.15	0.23	0.26	0.65	0.67	2.5	3.2	4.5	5.4	8.5	10.5	17.3	19.6	24.3	49.2		
Hub material		Al optional steel		Al optional steel		Al optional steel		Al optional steel		steel optional Al		steel optional Al		steel optional Al		steel optional Al		steel		steel	
Approximate weight (kg)		0.15		0.3		0.4		0.8		1.7		2.5		4		7.5		7		12	
Torsional stiffness (10 ³ Nm/rad)	C _T	20	15	39	28	76	55	129	85	175	110	191	140	450	350	510	500	780	1304		
Axial ± (mm)	Max. values	1	2	1	2	1.5	2	2	3	2	3	2	3	2.5	3.5	2.5	3.5	3.5	3.5		
Lateral ± (mm)		0.15	0.2	0.2	0.25	0.2	0.25	0.2	0.25	0.2	0.25	0.25	0.3	0.25	0.3	0.3	0.35	0.35	0.35		
Angular ± (degree)		1	1.5	1	1.5	1	1.5	1	1.5	1	1.5	1	1.5	1	1.5	1	1.5	1.5	1.5		
Axial spring stiffness (N/mm)	C _a	25	15	50	30	72	48	48	32	82	52	90	60	105	71	70	48	100	320		
Lateral spring stiffness (N/mm)	C _r	475	137	900	270	1200	420	920	290	1550	435	2040	610	3750	1050	2500	840	2000	3600		

* 1 Nm = 8.85 in lbs

Optional:



MODEL BKL

BACKLASH-FREE, TORSIONALLY STIFF METAL BELLOWS COUPLINGS



with clamping hubs

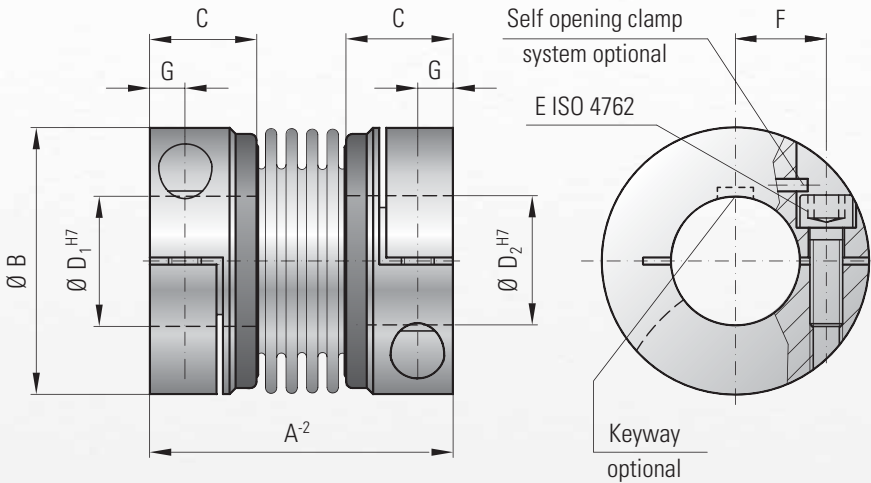

Ordering example

BKL / 80 / 26 / 22 / XX

Model
Series / Nm
Bore Ø D1 H7
Bore Ø D2 H7
Non standard e.g. stainless steel

Features:

- easy to mount
- low moment of inertia
- low cost

Material:

Bellows made from highly flexible, high grade stainless steel; see below for hub material

Design:

With a single ISO 4762 radial clamping screw per hub
Self opening clamp system optional: Loosening the clamping screw applies force to the pin, which forces the clamp into the open position for easy mounting and dismounting
Absolutely backlash free due to frictional clamp connection

Temperature range: -30 to +100° C (-22 to +212° F)

Speeds:

Up to 10,000 rpm; in excess of 10,000 rpm with finely balanced version (up to G = 2.5)

Service life:

Maintenance free with infinite life when operated within the technical specifications

Brief overloads:

Acceptable up to 1.5x the rated torque

Fit tolerance:

Overall clearance between hub and shaft 0.01-0.05 mm

Non standard applications:

Custom designs with various tolerances, keyways, materials, dimensions, etc. available upon request

Model BKL		Series									
		2	4.5	10	15	30	60	80	150	300	500
Rated torque (Nm)	T_{KN}	2	4.5	10	18	30	60	80	150	300	500
Overall length (mm)	A	30	40	44	58	68	79	92	92	109	114
Outside diameter (mm)	B	25	32	40	49	56	66	82	82	110	123
Fit length (mm)	C	10.5	13	13	21.5	26	28	32.5	32.5	41	42.5
Inside diameter possible from Ø to Ø H7 (mm)	$D_{1/2}$	4-12.7	6-16	6-24	8-28	10-32	14-35	16-42	19-42	24-60	35-62
Fastening screw ISO 4762	E	M3	M4	M4	M5	M6	M8	M10	M10	M12	M16
Tightening torque of the fastening screw (Nm)		2.3	4	4.5	8	15	40	70	85	120	200
Distance between centerlines (mm)	F	8	11	14	17	20	23	27	27	39	41
Distance (mm)	G	4	5	5	6.5	7.5	9.5	11	11	13	17
Moment of inertia (10^{-3} kgm ²)	J_{total}	0.002	0.007	0.016	0.065	0.12	0.3	0.75	1.8 0.8	7.5 3.1	11.7 4.9
Hub material		Al optional steel	Al optional steel	Al optional steel	Al optional steel	Al optional steel	Al optional steel	Al optional steel	steel optional Al	steel optional Al	steel optional Al
Approximate weight (kg)		0.02	0.05	0.06	0.16	0.25	0.4	0.7	1.7 0.75	3.8 1.6	4.9 2.1
Torsional stiffness (10^3 Nm/rad)	C_T	1.5	7	9	23	31	72	80	141	157	290
Axial ± (mm)	Max. values	0.5	1	1	1	1	1.5	2	2	2	2.5
Lateral ± (mm)		0.2	0.2	0.2	0.2	0.2	0.2	0.2	0.2	0.2	0.2
Angular ± (degree)		1	1	1	1	1	1	1	1	1	1
Axial spring stiffness (N/mm)	C_a	8	35	30	30	50	67	44	77	112	72
Lateral spring stiffness (N/mm)	C_r	50	350	320	315	366	679	590	960	2940	1450

* 1 Nm = 8.85 in lbs

Optional:



MODEL BKC

BACKLASH-FREE, TORSIONALLY STIFF METAL BELLOWS COUPLINGS



compact version with clamping hubs

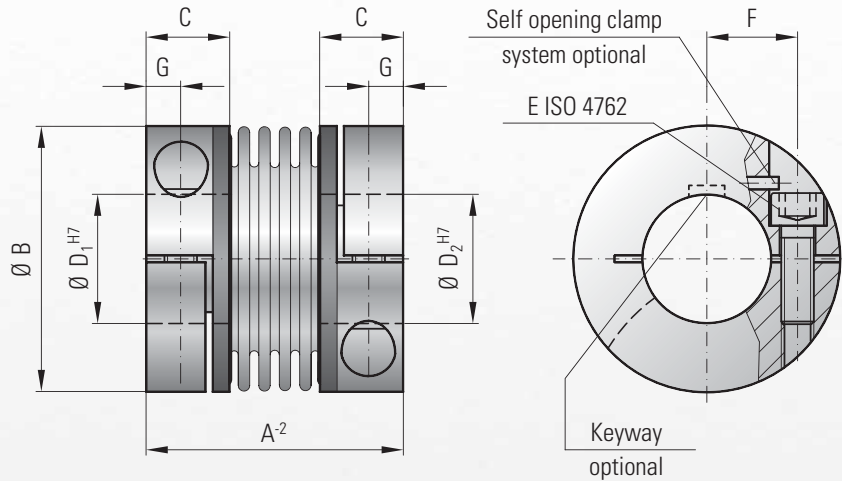

Features:

- high torsional rigidity
- easy to mount
- suited for space restricted installations
- low moment of inertia

Material:

Bellows made from highly flexible, high grade stainless steel; see below for hub material

Design:

With a single ISO 4762 radial clamping screw per hub

Self opening clamp system optional: Loosening the clamping screw applies force to the pin, which forces the clamp into the open position for easy mounting and dismounting

Absolutely backlash free due to frictional clamp connection

Temperature range: -30 to +100° C (-22 to +212° F)

Speeds:

Up to 10,000 rpm; in excess of 10,000 rpm with finely balanced version (up to G = 2.5)

Service life:

Maintenance free with infinite life when operated within the technical specifications

Brief overloads:

Acceptable up to 1.5x the rated torque

Fit tolerance:

Overall clearance between hub and shaft 0.01-0.05 mm

Non standard applications:

Custom designs with various tolerances, keyways, materials, dimensions, etc. available upon request

Ordering example

BKC / 60 / 26 / 22 / XX

Model
Series / Nm
Bore Ø D1 H7
Bore Ø D2 H7
Non standard e.g. stainless steel

Model BKC			Series					
			15	30	60	150	300	500
Rated torque (Nm)	T_{KN}	18	30	60	150	300	500	
Overall length (mm)	A^{-2}	48	58	67	78	94	100	
Outside diameter (mm)	B	49	56	66	82	110	123	
Fit length (mm)	C	16.5	21	23	27.5	34	34	
Inside diameter possible from Ø to Ø H7 (mm)	$D_{1/2}$	8-28	12-32	14-35	19-42	24-60	32-75	
Fastening screw ISO 4762		M5	M6	M8	M10	M12	M12	
Tightening torque of the fastening screw (Nm)	E	8	15	40	75	120	125	
Distance between centerlines (mm)	F	17.5	20	23	27	39	45	
Distance (mm)	G	6.5	7.5	9.5	11	13	13	
Moment of inertia (10^{-3}kgm^2)	J_{total}	0.05	0.1	0.26	0.65	6.3	9	
Hub material		Al	Al	Al	Al	steel	steel	
Approximate weight (kg)		0.13	0.21	0.37	0.72	3.26	3.52	
Torsional stiffness (10^9Nm/rad)	C_T	23	31	72	141	157	290	
Axial ± (mm)	Max. values	1	1	1.5	2	2	2.5	
Lateral ± (mm)		0.2	0.2	0.2	0.2	0.2	0.2	
Angular ± (degree)		1	1	1	1	1	1	
Axial spring stiffness (N/mm)	C_a	30	50	67	77	112	72	
Lateral spring stiffness (N/mm)	C_r	315	366	679	960	2940	2200	
Speed max. with G = 2.5 balancing (rpm)		80,000	70,000	60,000	50,000	40,000	30,000	

* 1 Nm = 8.85 in lbs

Optional:



MODEL BKM

BACKLASH-FREE, TORSIONALLY STIFF METAL BELLOWS COUPLINGS



rigid and compact, with clamping hubs

Features:

- ultra-compact design for high torques
- easy to mount
- suited for space restricted installations
- lowest moment of inertia

Material:

Bellows made from highly flexible, high grade stainless steel; see below for hub material

Design:

With a single ISO 4762 radial clamping screw per hub

Self opening clamp system optional: Loosening the clamping screw applies force to the pin, which forces the clamp into the open position for easy mounting and dismounting

Absolutely backlash free due to frictional clamp connection

Temperature range: -30 to +100° C (-22 to +212° F)

Speeds: Up to 10,000 rpm; in excess of 10,000 rpm with finely balanced version (up to G = 2.5)

Service life:

Maintenance free with infinite life when operated within the technical specifications

Brief overloads:

Acceptable up to 1.5x the rated torque

Fit tolerance:

Overall clearance between hub and shaft 0.01-0.05 mm

Non standard applications:

Custom designs with various tolerances, keyways, materials, dimensions, etc. available upon request

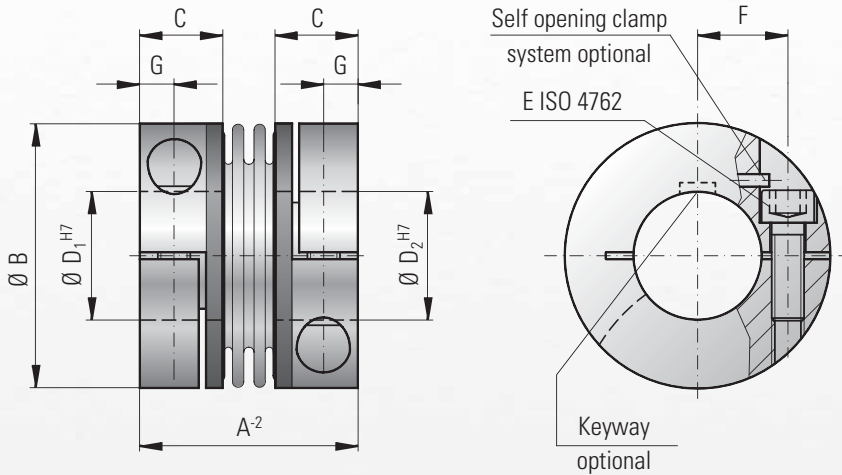

Ordering example

BKM / 20 / 24 / 15 / XX

- Model
- Series / Nm
- Bore Ø D1 H7
- Bore Ø D2 H7
- Non standard e.g. stainless steel

Model BKM		Series				
		20	200	400	1000	
Rated torque (Nm)	T_{KN}	20	200	400	1000	
Overall length (mm)	A^{-2}	40	59	75	89	
Outside diameter (mm)	B	49	66	82	110	
Fit length (mm)	C	16.5	23	27.5	34	
Inside diameter possible from Ø to Ø H7 (mm)	$D_{1/2}$	15-28	24-35	32-40	40-60	
Fastening screw ISO 4762	E	M5	M8	M10	M12	
Tightening torque of the fastening screw (Nm)		8	40	75	130	
Distance between centerlines (mm)	F	17	23	27	39	
Distance (mm)	G	6	9.5	11	13	
Moment of inertia (10^{-3} kgm^2)	J_1	0.05	0.18	0.62	7.2	
Hub material		Al	Al	Al	steel	
Approximate weight (kg)		0.13	0.4	0.7	3.5	
Torsional stiffness (10^3 Nm/rad)	C_T	41.9	138	170	570	
Axial	max. value	± (mm)	1	1.5	1	2
Lateral		± (mm)	0.06	0.08	0.1	0.1
Angular		± (degree)	0.5	0.5	0.5	0.5
Axial spring stiffness (N/mm)	C_a	55.8	153	114	148	
Lateral spring stiffness (N/mm)	C_r	3,710	11,000	6,058	9,010	
Speed max. with G = 2.5 balancing (rpm)		80,000	60,000	50,000	40,000	

* 1 Nm = 8.85 in lbs

Mounting example:

Possible mounting with a torque transducer

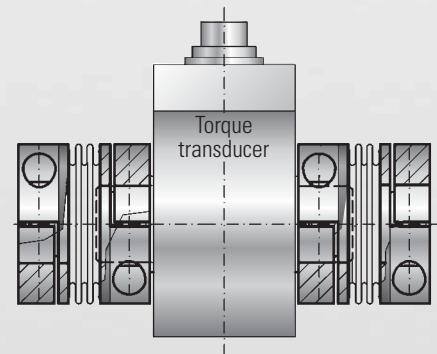

Smaller bore diameters at reduced torque capacities available upon request

Optional:



MODEL BKS

BACKLASH-FREE, TORSIONALLY STIFF METAL BELLOWS COUPLINGS



stainless steel, welded, with clamping hubs

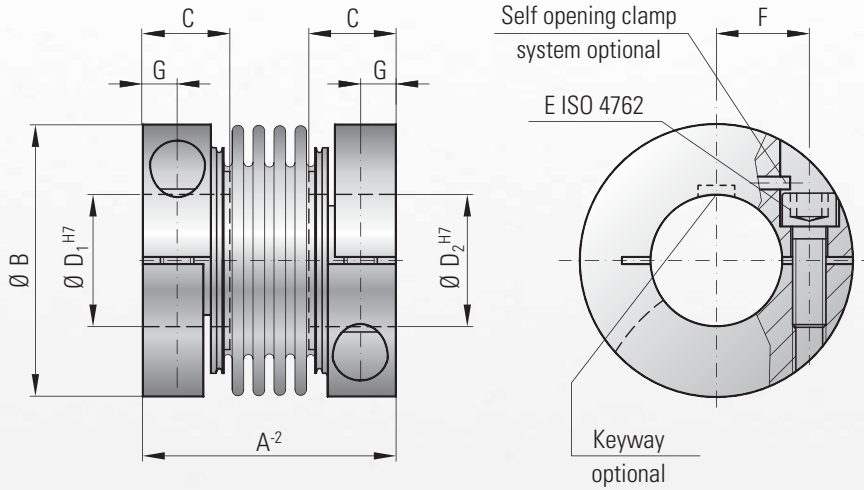

Features:

- for high temperatures
- compact
- easy to mount
- suited for space restricted installations

Material:

Bellows and clamping hubs, are made from stainless steel; screws plated (10.9)
Detailed specifications upon request

Design:

With a single ISO 4762 radial clamping screw per hub
Laser welded connection between hubs and bellows

Self opening clamp system optional: Loosening the clamping screw applies force to the pin, which forces the clamp into the open position for easy mounting and dismounting

Temperature range:

-40 to +300° C (-40 to +572° F)

Speeds:

Up to 10,000 rpm; in excess of 10,000 rpm with finely balanced version (up to G = 2.5)

Fit tolerance:

Overall clearance between hub and shaft
0.01-0.05 mm

Ordering example

BKS / 15 / 20 / 19 / XX

- Model
- Series
- Bore Ø D1 H7
- Bore Ø D2 H7
- Non standard e.g. finely balanced G=2.5

Model BKS			Series				
			15	30	60	150	300
Rated torque (Nm)	T_{KN}	25	40	80	200	350	600
Overall length (mm)	A^{-2}	45	52	66	76	89	95
Outside diameter (mm)	B	49	56	66	82	110	123
Fit length (mm)	C	17	20	24	30	34	35
Inside diameter possible from Ø to Ø H7 ** (mm)	D_1/D_2	12-28	14-32	16-35	19-42	24-60	32-75
Fastening screw ISO 4762	E	M5	M6	M8	M10	M12	M12
Tightening torque of the fastening screw (Nm)	E	8	15	40	75	120	125
Distance between centerlines (mm)	F	17.5	20	23	27	39	45
Distance (mm)	G	6	7.5	9.5	11	13	13
Moment of inertia (10^{-3} kgm ²)	$J_{ges.}$	0.1	0.2	0.53	1.5	5.5	8.1
Approximate weight (kg)		0.27	0.42	0.78	1.5	2.9	3.5
Torsional stiffness (10^9 Nm/rad)	C_T	23	31	72	141	157	290
Axial ± (mm)	Max. values	1	1	1.5	2	2	2.5
Lateral ± (mm)		0.2	0.2	0.2	0.2	0.2	0.2
Angular ± (degree)		1	1	1	1	1	1
Axial spring stiffness (N/mm)	C_a	30	50	67	77	112	72
Lateral spring stiffness (N/mm)	C_r	315	366	679	960	2940	2200
Speed max. with G = 2.5 balancing (rpm)		60,000	50,500	50,000	40,500	40,000	30,000

* 1 Nm = 8.85 in lbs

** Smaller bore diameter available at reduced torque capacity

Optional:



MODEL BK3

BACKLASH-FREE, TORSIONALLY STIFF METAL BELLOWS COUPLINGS

with tapered conical sleeves

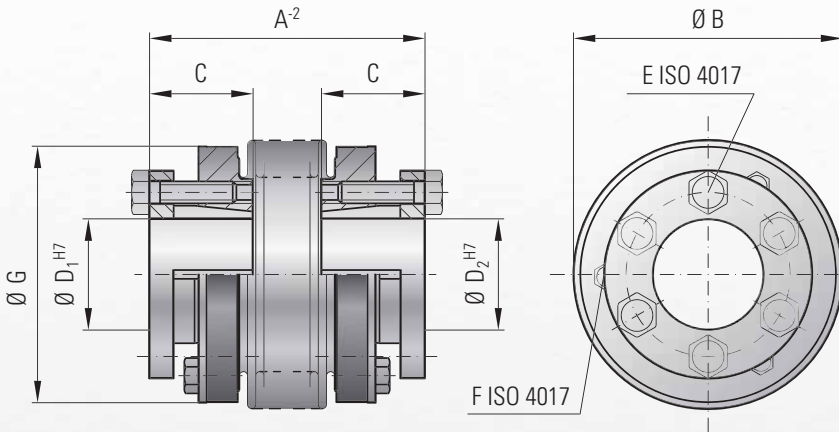

Ordering example

BK3 / 60 / 76 / 20 / 22 / XX

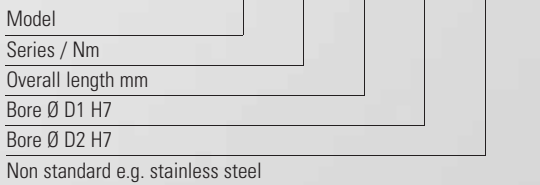

Features:

- high clamping force
- rugged, high torque design
- new jack screw design suited for space restricted applications

Material:

Bellows made from highly flexible, high grade stainless steel; hubs made from steel

Design:

With tapered conical sleeves and captive ISO 4017 jack screws
Absolutely backlash free due to frictional clamp connection

Temperature range:

-30 to +100° C (-22 to +212° F)

Speeds:

Up to 10,000 rpm; in excess of 10,000 rpm with finely balanced version (up to G = 2.5)

Service life:

Maintenance free with infinite life when operated within the technical specifications

Brief overloads:

Acceptable up to 1.5x the rated torque

Fit tolerance:

Overall clearance between hub and shaft 0.01-0.05 mm

Non standard applications:

Custom designs with various tolerances, keyways, materials, dimensions, etc. available upon request

Model BK 3		Series																							
		15		30		60		150		200		300		500		800		1500		4000		6000		10000	
Rated torque (Nm)	T_{KN}	15		30		60		150		200		300		500		800		1500		4000		6000		10000	
Overall length (mm)	A^{-2}	48	55	57	65	66	76	75	87	78	90	89	103	97	110	114	141	195	210	217					
Outside diameter of bellows (mm)	B	49		55		66		81		90		110		124		133		157		200		253		303	
Fit length (mm)	C	19		22		27		32		32		41		41		50		61		80		85		92	
Inside diameter possible from \emptyset to \emptyset H7 (mm)	$D_{1/2}$	10-22		12-23		12-29		15-38		15-44		24-56		24-60		30-60		35-70		50-100		60-140		70-180	
Fastening screws ISO 4017	E	6x M4		6x M5		6x M5		6x M6		6x M6		6x M8		6x M8		6x M10		6x M12		6x M16		6x M16		8x M16	
Tightening torque of the fastening screws (Nm)		4		6		8		12		14		18		25		40		70		120		150		160	
Jack screw ISO 4017	F	3x M4		3x M4		3x M5		3x M5		3x M6		3x M6		3x M6		3x M8		6x M8		6x M10		6x M10		8x M10	
Outside diameter of hub (mm)	G	49		55		66		81		90		110		122		116		135		180		246		295	
Moment of inertia (10^{-3} kgm ²)	J_{total}	0.07	0.08	0.15	0.16	0.39	0.41	1.2	1.6	1.7	2.5	5.1	5.9	9.1	9.9	13.2	34.9	85.5	254	629					
Approximate weight (kg)		0.25		0.4		0.7		1.2		1.8		3		4.2		5.6		8.2		23		32.6		45.5	
Torsional stiffness (10^3 Nm/rad)	C_T	20	15	39	28	76	55	175	110	191	140	450	350	510	500	780	1304	3400	5700	10950					
Axial ± (mm)	Max. values	1	2	1	2	1.5	2	2	3	2	3	2.5	3.5	2.5	3.5	3.5	3.5	3.5	3	3					
Lateral ± (mm)		0.15	0.2	0.2	0.25	0.2	0.25	0.2	0.25	0.25	0.3	0.25	0.3	0.3	0.35	0.35	0.35	0.4	0.4	0.4					
Angular ± (degree)		1	1.5	1	1.5	1	1.5	1	1.5	1	1.5	1	1.5	1	1.5	1.5	1.5	1.5	1.5	1.5					
Axial spring stiffness (N/mm)	C_a	25	15	50	30	72	48	82	52	90	60	105	71	70	48	100	320	565	1030	985					
Lateral spring stiffness (N/mm)	C_r	475	137	900	270	1200	420	1500	435	2040	610	3750	1050	2500	840	2000	3600	6070	19200	21800					

* 1 Nm = 8.85 in lbs

Optional:



MODEL BK5

BACKLASH-FREE, TORSIONALLY STIFF METAL BELLOWS COUPLINGS



blind mate with clamping hubs

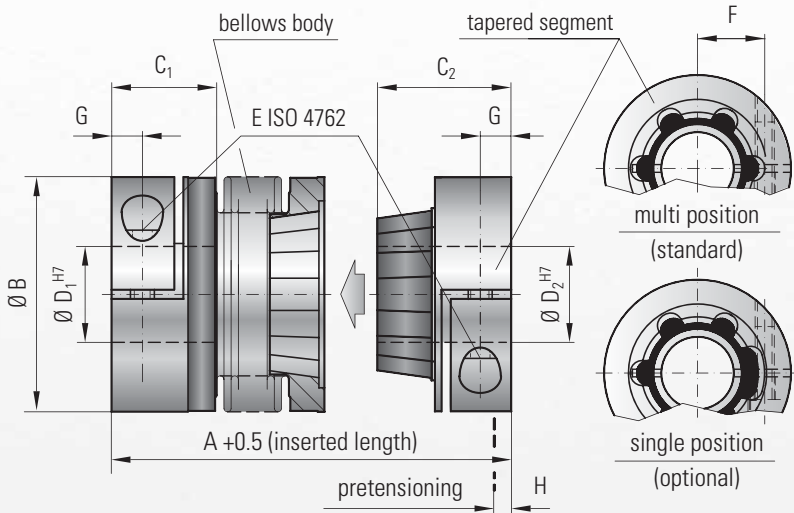

Features:

- absolutely backlash free and torsionally rigid
- easy mounting and dismounting
- electrically and thermally isolating
- wear and maintenance free
- low moment of inertia
- compensation for misalignment

Material:

Bellows made from highly flexible, high grade stainless steel; clamping hubs up to series 80 made from aluminum; series 150 and up made from steel. Bellows side adapter plate made from aluminum; series 800 and up made from steel. Tapered male segment made from glass reinforced plastic molded directly onto the clamping hub

Design:

With a single ISO 4762 radial clamping screw per hub. Absolutely backlash free due to frictional clamp connection and axial pretensioning of the tapered press fit segment

Temperature range: -30 to +100° C (-22 to +212° F)

Speeds:

Up to 10,000 rpm; in excess of 10,000 rpm with finely balanced version (up to G = 2.5)

Service life:

Maintenance free with infinite life when operated within the technical specifications

Brief overloads:

Acceptable up to 1.5x the rated torque

Fit tolerance:

Overall clearance between hub and shaft 0.01-0.05 mm

Ordering example

BK5 / 30 / 71 / 18 / 19 / XX

Model	BK5
Series / Nm	30
Overall length mm	71
Bore Ø D1 H7	18
Bore Ø D2 H7	19
Non standard e.g. single position engagement	XX

Model BK 5		Series																	
		15		30		60		80		150		300		500		800		1500	
Rated torque (Nm)	T _{KN}	15		30		60		80		150		300		500		800		1500	
Overall length (inserted) (mm)	A ^{+0.5}	60	67	71	79	85	95	94	106	95	107	114	128	136	149	150	172		
Outside diameter (mm)	B	49		55		66		81		81		110		124		133		157	
Fit length (mm)	C ₁	22		27		32		36		36		43		51		45		55	
Fit length (mm)	C ₂	28		33		39		43		43		52		61		74		94	
Inside diameter possible from Ø to Ø H7 (mm)	D ₁	8-28		10-30		12-32		14-42		14-42		24-60		35-60		40-75		50-80	
Inside diameter possible from Ø to Ø H7 (mm)	D ₂	8-22		10-25		12-32		14-38		19-38		24-58		35-60		40-62		50-75	
Fastening screw ISO 4762	E	M5		M6		M8		M10		M10		M12		M16		2 x M16**		2 x M20**	
Tightening torque (Nm)		8		15		40		50		70		130		200		250		470	
Distance between centerlines (mm)	F	17		19		23		27		27		39		41		2 x 48**		2 x 55**	
Distance (mm)	G	6.5		7.5		9.5		11		11		13		16.5		18		22.5	
Approximate pretensioning (mm)	H	0.2 up to 1.0		0.5 up to 1.0		0.5 up to 1.5		0.5 up to 1.5		0.5 up to 1.5		0.5 up to 1.5		1.0 up to 2.0		1.0 up to 2.5		0.5 up to 1.5	
Axial recovery force at maximum pretensioning (N)		20	12	50	30	70	45	48	32	82	52	157	106	140	96	200	650		
Moment of inertia (10 ⁻³ kgm ²)	J _{total}	0.07	0.08	0.14	0.15	0.23	0.26	0.65	0.67	2.2	2.4	7.4	7.9	13.7	14.4	26.2	51.4		
Approximate weight (kg)		0.1	0.1	0.3	0.3	0.4	0.4	0.9	0.9	1.8	1.8	4	4	6.5	6.7	8.2	15.3		
Torsional stiffness (10 ³ Nm/rad)	C _T	10	8	20	14	38	28	65	43	88	55	225	175	255	245	400	650		
Axial* ± (mm)	Max. values	0.5	1	0.5	1	0.5	1	1	2	1	2	1.5	2	2.5	3.5	3	2		
Lateral ± (mm)		0.15	0.2	0.2	0.25	0.2	0.25	0.2	0.25	0.2	0.25	0.25	0.3	0.3	0.35	0.35	0.35		
Angular ± (degree)		1	1.5	1	1.5	1	1.5	1	1.5	1	1.5	1	1.5	1	1.5	1.5	1.5		
Lateral spring stiffness (N/mm)		C _r	475	137	900	270	1200	420	920	290	1550	435	3750	1050	2500	840	2000	3600	

* in addition to maximum pretensioning

** two screws per hub, 180 degrees opposed

1 Nm = 8.85 in lbs

Optional:



MODEL BK6

BACKLASH-FREE, TORSIONALLY STIFF METAL BELLOWS COUPLINGS



blind mate with clamping ring

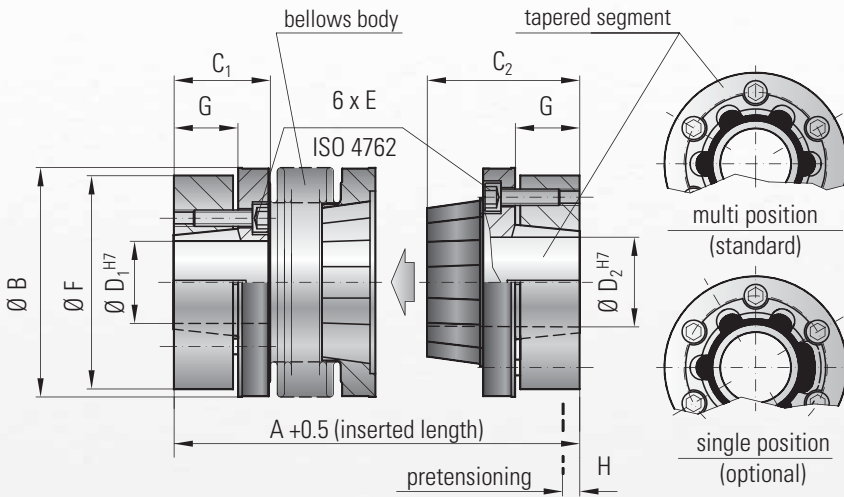

axial mounting for space restricted applications

Ordering example

BK6 / 30 / 71 / 18 / 19 / XX

Model
Series / Nm
Overall length mm
Bore Ø D1 H7
Bore Ø D2 H7
Non standard e.g. single position engagement

Features:

- torsionally rigid
- easy mounting and dismounting
- electrically and thermally isolating
- wear and maintenance free
- absolutely backlash free due to frictional clamp connection and axial pretensioning of the tapered press fit segment

Material:

Bellows made from highly flexible, high grade stainless steel; conical clamping hubs made from steel. Bellows side adapter plate made from aluminum; series 800 and up made from steel. Tapered male segment made from glass reinforced plastic molded directly onto the clamping hub.

Design:

Bellows body and male tapered segment with conical clamping ring, 6x ISO 4762 fastening screws and 3x threaded holes for removal.

Temperature range: -30 to +100° C (-22 to +212° F)

Speeds:

Up to 10,000 rpm; in excess of 10,000 rpm with finely balanced version (up to G = 2.5)

Service life:

Maintenance free with infinite life when operated within the technical specifications

Brief overloads:

Acceptable up to 1.5x the rated torque

Fit tolerance:

Overall clearance between hub and shaft 0.01-0.05 mm

Model BK 6		Series																										
		15		30		60		150		300		500		800		1500												
Rated torque (Nm)	T_{KN}	15		30		60		150		300		500		800		1500												
Overall length (inserted) (mm)	$A^{+0.5}$	58	65	68	76	79	89	97	109	113	127	132	145	140	158	158	158											
Outside diameter (mm)	B	49		55		66		81		110		124		133		157												
Fit length (mm)	C_1	13.5		16.5		18		23.5		27		32		42		53												
Fit length (mm)	C_2	29		34		39		49.5		59		68		74		90.5												
Inside diameter possible from Ø to Ø H7 (mm)	D_1	10-22		12-24		12-32		15-40		24-56		30-60		40-62		50-75												
Inside diameter possible from Ø to Ø H7 (mm)	D_2	10-22		12-24		12-32		15-40		24-56		30-60		40-62		50-75												
Fastening screw ISO 4762	E	M4		M5		M5		M6		M8		M8		M10		M12												
Tightening torque (Nm)		3.5		6.5		8		12		30		32		55		110												
Diameter of clamping ring (mm)	F	46.5		51		60		74		102		114		126		146												
Clamping ring length (mm)	G	9.5		10.5		11.5		17.5		20		23		27		32												
Approximate pretensioning (mm)	H	0.2 up to 1.0		0.5 up to 1.0		0.5 up to 1.5		0.5 up to 1.5		0.5 up to 1.5		1.0 up to 2.0		1.0 up to 2.0		0.5 up to 1.5												
Axial recovery force at maximum pretensioning (N)		20		12		50		30		70		45		82		52		157		106		140		96		400		650
Moment of inertia (10^{-3} kgm ²)	J_{total}	0.1	0.12	0.2	0.25	0.4	0.45	2.0	2.5	5.4	6.1	8.4	9.1	19.5	19.5	44	44											
Approximate weight (kg)		0.3	0.32	0.5	0.52	0.82	0.84	1.6	1.7	4.1	4.2	6.0	6.3	9.4	9.4	16.2	16.2											
Torsional stiffness (10^3 Nm/rad)	C_T	10	8	20	14	38	28	88	55	225	175	255	245	400	400	660	660											
Axial* ± (mm)	Max. values	0.5	1	0.5	1	0.5	1	1	2	1.5	2	2.5	3.5	3	3	2	2											
Lateral ± (mm)		0.15	0.2	0.2	0.25	0.2	0.25	0.2	0.25	0.25	0.3	0.3	0.35	0.35	0.35	0.35	0.35											
Angular ± (degree)		1	1.5	1	1.5	1	1.5	1	1.5	1	1.5	1	1.5	1.5	1.5	1.5	1.5											
Lateral spring stiffness (N/mm)		C_r	475	137	900	270	1200	420	1550	435	3750	1050	2500	840	2000	2000	3600	3600										

* in addition to maximum pretensioning

Higher torques upon request

1 Nm = 8.85 in lbs

Optional:



MODEL BK7

BACKLASH-FREE, TORSIONALLY STIFF METAL BELLOWS COUPLINGS

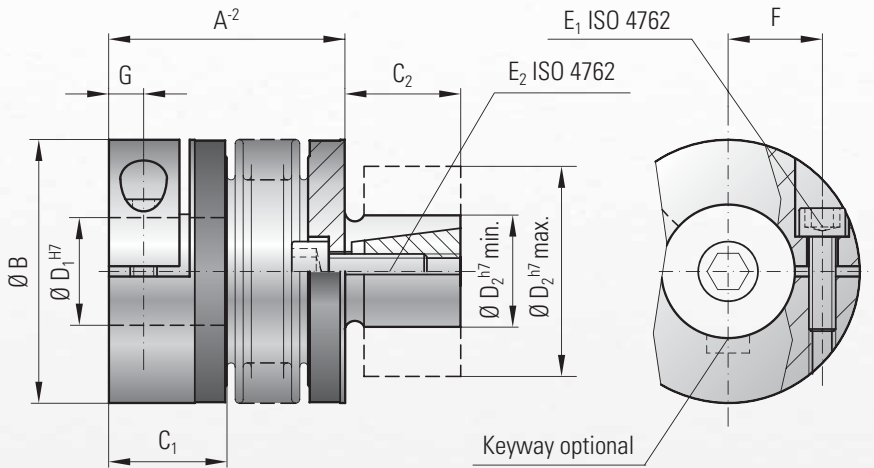

with expanding shaft

Features:

- for easy hollow shaft mounting
- compact design, conserves space while saving cost
- adapts mismatched shaft and bore diameters
- backlash free and torsionally rigid
- low moment of inertia

Material:

Bellows made from highly flexible, high grade stainless steel; see below for hub material. Expanding shaft and cone made from steel.

Design:

With a single ISO 4762 radial clamping screw on one hub. Shaft with internal cone for expansion. Absolutely backlash free due to frictional clamp connection.

Temperature range: -30 to +100° C (-22 to +212° F)

Speeds:

Up to 10,000 rpm; in excess of 10,000 rpm with finely balanced version (up to G = 2.5)

Service life:

Maintenance free with infinite life when operated within the technical specifications

Brief overloads:

Acceptable up to 1.5x the rated torque

Fit tolerance:

Overall clearance between hub and shaft 0.01-0.05 mm

Non standard applications:

Custom designs with various tolerances, keyways, materials, dimensions, etc. available upon request

Ordering example

BK7 / 150 / 71 / 32 / 35 / XX

Model
Series / Nm
Overall length mm
Bore Ø D1 H7
Shaft Ø D2 h7
Non standard e.g. stainless steel

Model BK 7		Series									
		15		30		60		150		300	
Rated torque (Nm)	T_{KN}	15	30	60	150	300					
Overall length (inserted) (mm)	A^2	45	52	53	61	62	72	71	83	84	98
Outside diameter (mm)	B	49	55	66	81	110					
Fit length (mm)	C_1	22	27	32	36	43					
Fit length (mm)	C_2	20	25	27	32	45					
Inside diameter possible from Ø to Ø H7 (mm)	D_1	8-28	10-30	12-35	19-42	30-60					
Shaft diameter from Ø to Ø h7 (mm)	D_2	13-25	14-30	23-38	26-42	38-60					
Fastening screw ISO 4762	$E_{1/2}$	M5	M6	M8	M10	M12					
Tightening torque of the fastening screw (Nm)	$E_{1/2}$	8	14	38	65	120					
Distance between centerlines (mm)	F	17	19	23	27	39					
Distance (mm)	G	6.5	7.5	9.5	11	13					
Moment of inertia (10^{-3} kgm ²)	J_{total}	0.07	0.08	0.14	0.15	0.23	0.26	2.2	2.4	6.5	8.9
Hub material		Al	Al	Al	steel	steel					
Approximate weight (kg)		0.15	0.3	0.4	1.7	4					
Torsional stiffness (10^3 Nm/rad)	C_T	20	15	39	28	76	55	175	110	450	350
Axial ± (mm)	Max. values	1	2	1	2	1.5	2	2	3	2.5	3.5
Lateral ± (mm)		0.15	0.2	0.2	0.25	0.2	0.25	0.2	0.25	0.25	0.3
Angular ± (degree)		1	1.5	1	1.5	1	1.5	1	1.5	1	1.5
Axial spring stiffness (N/mm)	C_a	20	12	50	30	72	48	82	52	105	71
Lateral spring stiffness (N/mm)	C_r	315	108	730	230	1200	380	1550	435	3750	1050

* 1 Nm = 8.85 in lbs

Installation instructions:

Tightening the screw (2) through the bellows body draws in the cone (3) which causes the shaft (1) to expand. The recommended bore tolerance is ISO H7.

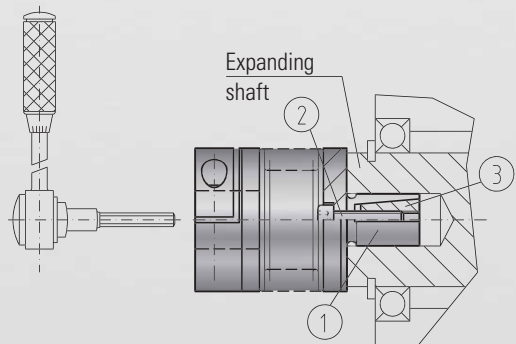

Optional:



MODEL BK8

BACKLASH-FREE, TORSIONALLY STIFF METAL BELLOWS COUPLINGS



ISO flange mounting

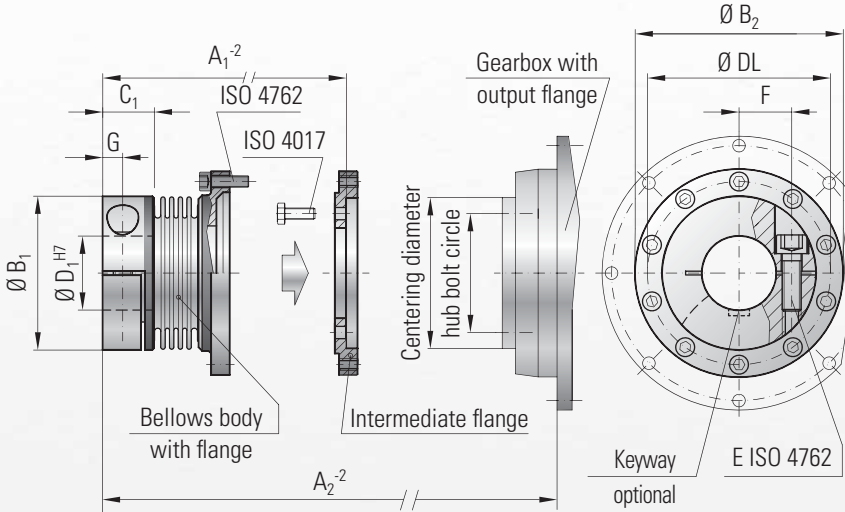

Ordering example

BK8 / 15 / 24 / 40 / XX

Model
Series
Bore $\varnothing D H7$
Flange centering diameter $\varnothing 40 h7$
Non standard e.g. stainless steel

Coupling available without intermediate flange.

Model BK 8		Series				
		15	60	150	300	1500
Flange centering diameter (mm)		40 h7	63 h7	80 h7	100 h7	160 h7
Flange bolt circle / thread \varnothing (mm)		31.5 8x M5	50 8x M6	63 12x M6	80 12x M8	125 12x M10
Maximum torque* (Nm)		50	210	380	750	2600
Length -2 (mm)	A_1	48.5	67	72	90	140
Length -2 (mm)	A_2	68	97	101	128	190
Outside diameter (mm)	B_1	49	66	82	110	157
Flange diameter (mm)	B_2	63.5	86	108	132	188
Fit length (mm)	C	16.5	23	27.5	34	55
Inside diameter possible from \varnothing to $\varnothing H7$ (mm)	D	12-28	14-35	19-42	24-60	50-80
Hub bolt circle (mm)	DL	56.5	76	97	120	170
Fastening threads		10 x M4	10 x M5	10 x M6	12 x M6	18 x M8
Fastening screws ISO 4762	E	1 x M5	1 x M8	1 x M10	1 x M12	2 x M20
Tightening torque (Nm)		8	45	80	120	470
Distance (mm)	F	1 x 17.5	1 x 23	1 x 27	1 x 39	2 x 55
Distance (mm)	G	6.5	9.5	11	13	22.5
Approximate weight (kg)		0.3	0.7	1	2.8	10
Moment of inertia (10^{-3} kgm^2)	J_{ges}	0.15	0.65	1.3	5.5	45
Lateral \pm (mm)	Max. value	0.25	0.25	0.25	0.25	0.25
Angular \pm (degree)		1	1	1	1	1
Axial \pm (mm)		1	1.5	2	2.5	3

* maximum torque transmittable only for brief periods and requires maximum bore for clamping strength

1 Nm = 8.85 in lbs

Features:

- backlash free with high torsional rigidity
- easy mounting and dismantling
- suited for space restricted installations
- high transmittable torques with compact design

Material:

Bellows made from highly flexible, high grade stainless steel; the hubs are made from aluminium (series 300 and 1,500 are made from steel); the intermediate flange is made from steel (standard).

Design:

With a single ISO 4762 radial screw on clamping hub. Flange hub with separate intermediate flange for mounting to gearbox.

Speeds: Up to 10,000 rpm

Temperature range: -30 to +100° C (-22 to +212° F)

Fit tolerance:

Overall clearance between hub and shaft 0.01-0.05 mm

Non standard applications:

Custom designs with various tolerances, keyways, materials, dimensions, etc. available upon request

Gearbox with output flange

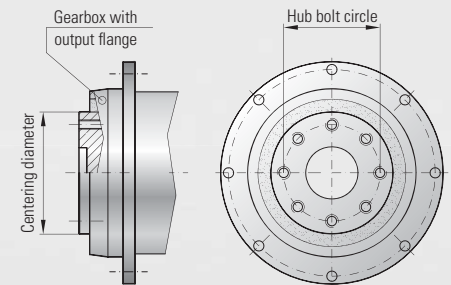

The bolt circle will be machined to match the gearbox

Mounting and dismantling

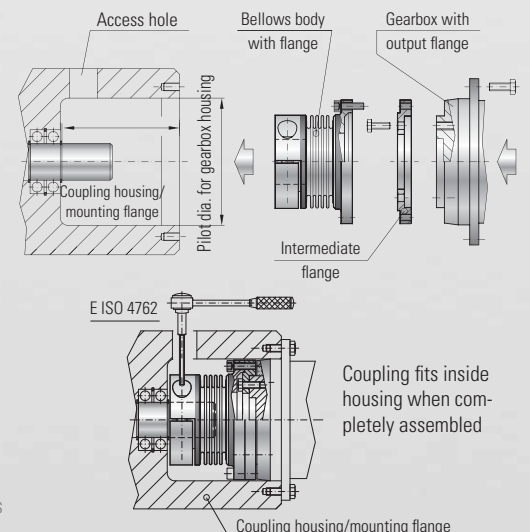

Optional:



TORSIONALLY STIFF, HIGH TORQUE BELLOWS COUPLINGS

Areas of application:

- Rolling mills
- Extruders and mixers
- Presses and stamping machinery
- Machine tools
- Crushers and shredders
- Test stands
- Compressors
- Agitators
- Wind turbines

Features:

- robust construction
- high torsional rigidity
- high operational dependability
- easy mounting and dismounting
- maintenance free
- precise transmission of angle and torque
- low restoring forces
- compensation for shaft misalignment
- quiet, smooth running operation
- temperatures up to 300° C (572° F)

MODELS

FEATURES

APPLICATION EXAMPLES

BX 1



**with flange mounting
from 10-100 KNm**

- special design applications
- available with custom or standard flanges

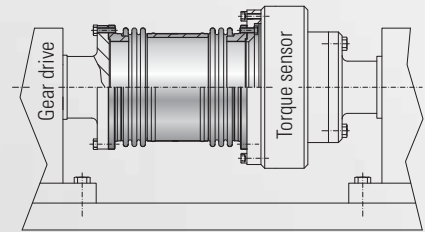

see page 18

BX 4



**with keyway connection
from 10-100 KNm**

- low backlash (keyway connection)
- compact, simple design

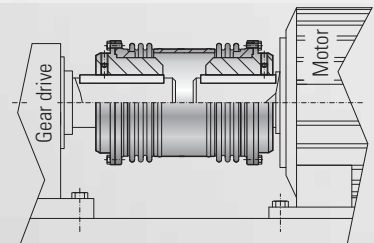

see page 19

BX 6



**with conical clamping ring
from 10-100 KNm**

- backlash free conical clamp connection
- high clamping force

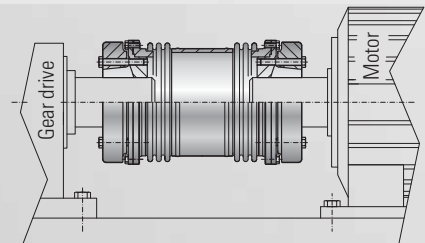

see page 20

Optional:



MODEL BX 1

BACKLASH-FREE, TORSIONALLY STIFF METAL BELLOWS COUPLINGS



with flange mounting

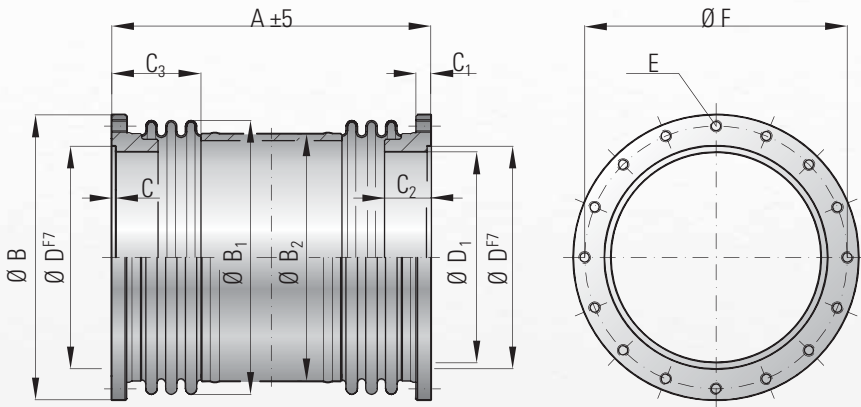

Ordering example

BX 1 / 50 / XX

Model
Series / KNm
Non standard e.g. stainless steel

Features:

- for high torque applications
- compact, simple design
- easy mounting and dismounting
- backlash free and torsionally rigid
- various overall lengths available
- high misalignment compensation

Material:

Bellows made from highly flexible, high grade stainless steel; hubs made from steel

Design:

Flange mount hubs on both sides; 2x bellows with intermediate tube (Series 10 without intermediate tube); welded connection between hubs and bellows

Fit tolerance:

Overall clearance between centering diameters 0.03-0.08 mm

Temperature range:

-40 to +300° C (-40 to +572° F)

Non standard applications:

Custom designs with various tolerances, keyways, materials, dimensions, etc. available upon request

Model BX 1			Series				
			10	25	50	75	100
Rated torque	(KNm)	T_{KN}	10	25	50	75	100
Maximum torque	(KNm)	T_{Kmax}	15	38	75	113	150
Overall length	(mm)	$A_{\pm 5}$	125	380	450	580	640
Outside diameter of flange	(mm)	B	310	336	398	449	545
Outside diameter of bellows ± 2	(mm)	B_1	300	323	370	412	520
Outside diameter of tube	(mm)	B_2	—	273	324	360	460
Fit length	(mm)	$C_{\pm 0.5}$	4	5	6	10	15
Thread depth	(mm)	C_1	15	25	30	36	36
Hub length	(mm)	C_2	24	76	74	93	110
Bellows body length +3	(mm)	C_3	—	115	130	160	170
Centering diameter f7	(mm)	D	265	260	310	350	440
Hub diameter +0.3	(mm)	D_1	250	240	290	320	390
Fastening threads			20xM12	24xM16	24xM20	20xM24	24xM24
Tightening torque of the fastening screws (screw grade 10.9)	(Nm)	E	120	300	580	1000	1000
Bolt circle diameter ± 0.4	(mm)	F	290	304	361	404	500
Moment of inertia	(10^{-3} kgm ²)	$J_{ges.}$	101	548	1185	2725	7900
Approximate weight	(kg)		8.3	27.8	43.7	80	151
Axial	\pm (mm)	Max. value	3	5	6	7	8
Lateral	\pm (mm)		0.4	2.2	2.5	3	3.5
Angular	\pm (degree)		1.5	1	1	1	1
Torsional stiffness coupling	(10^3 Nm/rad)		20,000	9,000	15,500	23,000	35,000
Axial spring stiffness bellows	(N/mm)		985	3,000	4,300	3,900	2,800
Lateral spring stiffness bellows	(KN/mm)		21	133	207	175	219

Optional:



MODEL BX 4

BACKLASH-FREE, TORSIONALLY STIFF METAL BELLOWS COUPLINGS



with keyway connection

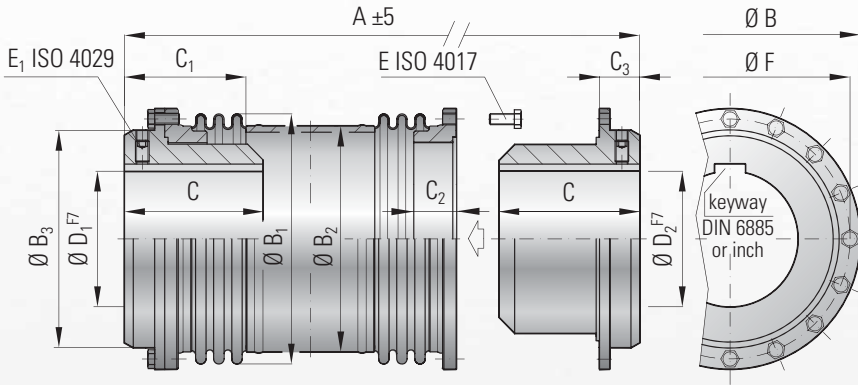

Features:

- for high torque applications
- compact, simple design
- easy mounting and dismounting
- torsionally rigid
- various overall lengths available
- high misalignment compensation

Material:

BelloWS made from highly flexible, high grade stainless steel; hubs made from steel

Design:

With removable coupling hubs with keyway on both sides; 2x bellows with intermediate tube (Series 10 without intermediate tube); welded connection between hubs and bellows

Fit tolerance:

Overall clearance between hub and shaft 0.03-0.08 mm

Temperature range:

-40 to +300° C (-40 to +572° F)

Non standard applications:

Custom designs with various tolerances, keyways, materials, dimensions, etc. available upon request

Ordering example

BX 4 / 50 / 120 / 200 / XX

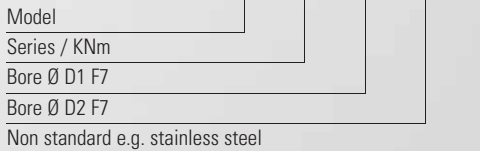

Model BX 4			Series				
			10	25	50	75	100
Rated torque	(KNm)	T_{KN}	10	25	50	75	100
Maximum torque	(KNm)	T_{Kmax}	15	38	75	113	150
Overall length	(mm)	$A_{\pm 5}$	210	480	590	760	840
Outside diameter of flange	(mm)	B	310	336	398	449	545
Outside diameter of bellows ± 2	(mm)	B_1	300	323	370	412	520
Outside diameter of tube	(mm)	B_2	-	273	324	360	460
Hub diameter	(mm)	B_3	255	260	310	350	440
Fit length	(mm)	C	95	130	200	240	280
Length ± 3	(mm)	C_1	-	170	200	257	260
Hub length	(mm)	C_2	24	81	80	103	120
Distance	(mm)	C_3	42	50	70	90	97
Inside diameter possible from \emptyset to $\emptyset F7$	(mm)	D_1/D_2	50 - 180	60 - 170	80 - 200	100 - 230	120 - 280
Fastening screw ISO 4017 / Tightening torque	(Nm)	E	20xM12 / 120	24xM16 / 300	24xM20 / 580	20xM24 / 1000	24xM24 / 1000
Fastening screw ISO 4029 / Tightening torque	(Nm)	E_1	M12 / 100	M16 / 220	M20 / 450	M24 / 800	M24 / 800
Bolt circle diameter ± 0.4	(mm)	F	290	304	361	404	500
Moment of inertia (10^{-3} kgm^2)		$J_{ges.}$	492	1272	3270	6754	19350
Approximate weight	(kg)		44.7	85	164	260	477
Axial \pm (mm)		Max. value	3	5	6	7	8
Lateral \pm (mm)			0.4	2.2	2.5	3	3.5
Angular \pm (degree)			1.5	1	1	1	1
Torsional stiffness coupling (10^3 Nm/rad)			20,000	9,000	15,500	23,000	35,000

Optional:



MODEL BX 6

BACKLASH-FREE, TORSIONALLY STIFF METAL BELLOWS COUPLINGS

with removable conical clamping hubs

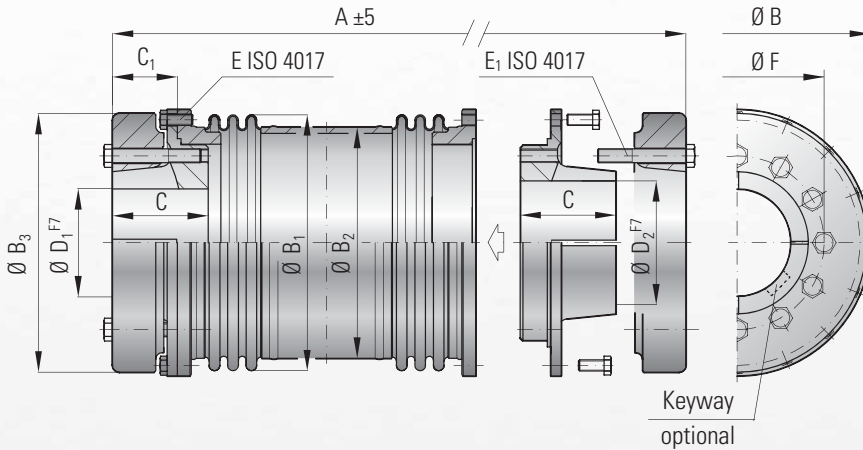

Ordering example

BX 6 / 50 / 120 / 120 / XX

Model
Series / KNm
Bore Ø D1 F7
Bore Ø D2 F7
Non standard e.g. stainless steel

Features:

- for high torque applications
- compact, simple design
- easy mounting and dismounting
- backlash free and torsionally rigid
- various overall lengths available
- high misalignment compensation

Material:

Bellows made from highly flexible, high grade stainless steel; hubs made from steel

Design:

With flange and removable conical clamping ring assemblies on both ends. The fastening screws for mounting the flange double as the removal jack screws for the conical clamping rings; 2x bellows with intermediate tube (Series 10 without intermediate tube); welded connection between hubs and bellows

Fit tolerance:

Overall clearance between hub and shaft 0.03-0.08 mm

Temperature range:

-40 to +300° C (-40 to +572° F); reduced ratings at higher temperatures

Non standard applications:

Custom designs with various tolerances, keyways, materials, dimensions, etc. available upon request

Model BX 6		Series				
		10	25	50	75	100
Rated torque (KNm)	T_{KN}	10	25	50	75	100
Maximum torque (KNm)	T_{Kmax}	15	38	75	113	150
Overall length (mm)	$A_{\pm 5}$	235	530	650	840	940
Outside diameter of flange (mm)	B	310	336	398	449	545
Outside diameter of bellows ±2 (mm)	B_1	300	323	370	412	520
Outside diameter of tube (mm)	B_2	-	273	324	360	460
Diameter of clamping ring (mm)	B_3	300	310	380	420	530
Fit length (mm)	C	90	110	140	170	200
Distance (mm)	C_1	55	74	99	130	150
Inside diameter possible from Ø to Ø F7 (mm)	D_1/D_2	70 - 170	80 - 180	100 - 200	130 - 230	150 - 280
Fastening screw ISO 4017 for mounting flange (mm)	E	20 x M12	24 x M16	24 x M20	20 x M24	24 x M24
Tightening torque (Nm)		120	300	580	1000	1000
Fastening screw ISO 4017 for conical clamping ring (mm)	E_1	8 x M16	12 x M16	12 x M20	16 x M20	12 x M24
Tightening torque (Nm)		200	250	300	350	600
Bolt circle diameter ±0.4 (mm)	F	210	220	250	290	360
Moment of inertia (10^{-3} kgm ²)	$J_{ges.}$	828	1535	3799	8277	24876
Approximate weight (kg)		60	93	168	280	550
Axial ± (mm)	Max. value	3	5	6	7	8
Lateral ± (mm)		0,4	2,2	2,5	3	3,5
Angular ± (degree)		1,5	1	1	1	1
Torsional stiffness coupling (10^3 Nm/rad)		20,000	9,000	15,500	23,000	35,000

Optional:



INSTALLATION INSTRUCTIONS

SERIES BX

Installing the coupling with fixed shafts (BX4 / BX6)

The intermediate section (BX1) can be installed at an angle after the mounting hubs have been put into place. The hubs can then be bolted to the intermediate section.

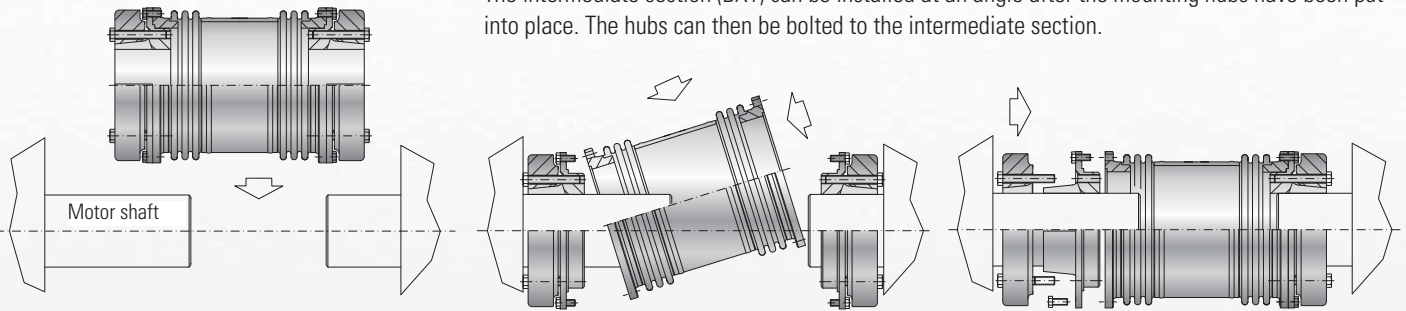

Mounting and dismounting of BX4

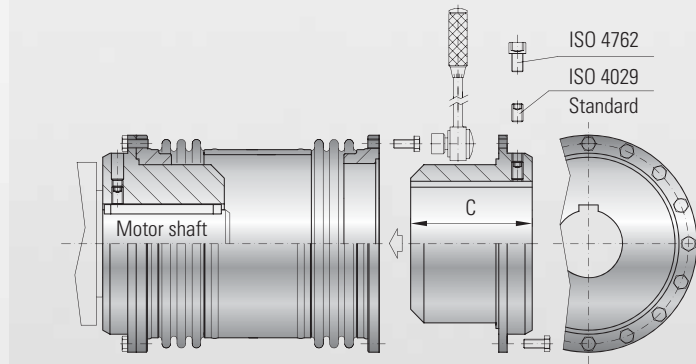

The maximum transmittable torque of the coupling depends on the bore diameter. See table below.

The full transmittable torque is only achieved through the use of a key that extends through the complete fit length (Dimension C).

With reduced key fit lengths, the maximum transmittable torque is reduced.

The coupling is axially secured through the use of radial set screws.

Mounting and dismounting of BX6

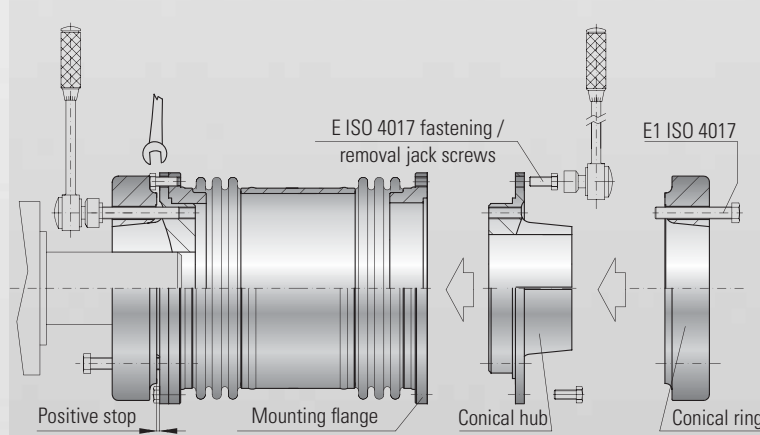

The conical hub is inserted into the mounting flange and secured with fastening screws. See page 20 for tightening torque values (E).

The fastening screws can also be used as removal jack screws for the conical ring.

The conical ring can be tightened after the conical hub has been bolted to the mounting flange.

Carefully tighten the fastening screws (E1) in a crosswise pattern several times around, gradually increasing the tightening torque until the conical ring makes contact with the conical hub.

The tightening torque of the conical ring fastening screws is very important when installing the coupling. See page 20 for tightening torque values (E1).

Maximum transmittable torque

Maximum transmittable torque of the keyway connection (model BX4) in KNm

These values are only valid for DIN 6885 keyway specifications (Contact R+W for inch size and non standard keyways)

Series	Ø 60	Ø 80	Ø 100	Ø 120	Ø 140	Ø 160	Ø 170	Ø 180	Ø 200	Ø 220	Ø 230	Ø 240	Ø 260	Ø 280
10	x	x	x	x	x	x	x	x	x	x	x	x	x	x
25	7	12	18	26	34	44	46	x	x	x	x	x	x	x
50	x	19	28	40	52	67	71	84	94	x	x	x	x	x
75	x	x	34	47	62	81	85	101	112	136	142	x	x	x
100	x	x	x	55	74	94	100	118	131	159	166	189	205	220

Optional:



MODEL ATEX

FOR USE IN HAZARDOUS AREAS AND EXPLOSIVE ATMOSPHERE

The ATEX 95a is regulated by the new European directive. Generally the explosive atmosphere is classified in 3 different zones.

Zone 0:

A place in which an explosive atmosphere consists of a mixture of air and flammable substances in the form of gas, vapor or mist and is present **frequently, continuously** or for **extended periods**.

Zone 20:

Is relevant for an explosive atmosphere in the form of clouds of combustible dust in air under the same conditions as above.

Zone 1:

Described as a place in which an explosive atmosphere consists of a mixture of air with flammable substances in the form of gas, vapor or mist, and is likely to occur in normal operation **occasionally**.

Zone 21:

Is relevant for an explosive atmosphere in the form of clouds of combustible dust in air under the same conditions as above.

Zone 2:

A place in which an explosive atmosphere consists of a mixture of air with flammable substances in the form of gas, vapor or mist and is not likely to occur in normal operation but, if it does occur, it will persist for only a **short period**.

Zone 22:

Relevant for an explosive atmosphere in the form of a cloud of combustible dust in air under the same conditions as above.

For the classified zones 1/21 and 2/22 the metal bellows couplings BK-EEEx do have an accreditation according to ATEX 95a

Installing the EEx bellows couplings

The entire coupling body must be covered by an electrically conductive plate.

Sealing according to IP2X or greater

Fit Tolerance: Overall clearance between hub and shaft 0.01-0.05 mm

Mounting: To ensure proper installation, the tightening torque values of the clamping screws (1) must be followed.

WARNING!

Constant monitoring of driving and driven shaft rotation required
Immediate shut down must be activated in case of interruption of rotational transmission



AT mosphere EX possible

Sizing and selection:

For safety purposes, all misalignment values and torque ratings must be decreased by 20%

Installation and operation:

Proper installation and operation are essential to the performance of BK-EEEx bellows couplings

Including:

- Sizing and selection of BK-EEEx bellows couplings
- Proper tightening torque and misalignment values
- Careful installation
- Maintenance intervals
- Troubleshooting
- Quality manufacturing
- Certification of conformity

Identification:

All BK-EEEx couplings are permanently labeled to display manufacturer and accreditation data

Sample accreditation data:



Type: BKL 150 EEx-2003
II 2 G D
EEx cT4/135°C
Ser.No.: A 44305
Tech.Ref.No.:2003/003RW

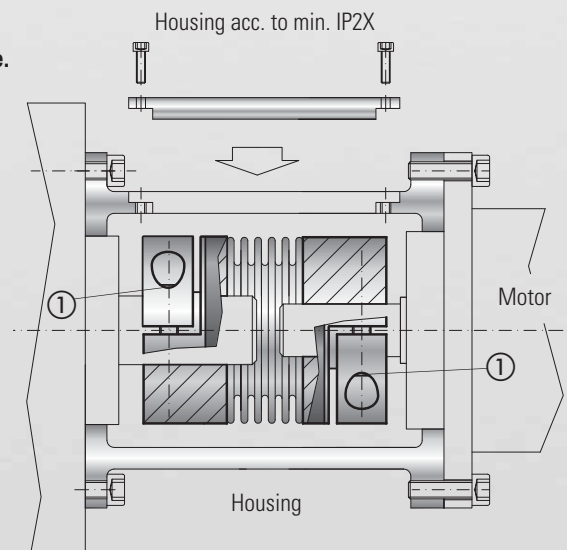

THE SELECTION

THE SELECTION PROCESS FOR TORSIONALLY RIGID BELLOWS COUPLINGS

According to Torque

In most cases couplings are rated according to the peak torque to be regularly transmitted.

The peak torque may not exceed the rated torque of the coupling.

The "rated torque" of the coupling is intended to represent the maximum torque which will regularly occur within a normal machine cycle, and within the acceptable coupling speed and misalignment ranges.

The following calculation has proven itself to be a good rule of thumb:

$$T_{KN} \geq 1,5 \cdot T_{AS} \quad (\text{Nm})$$

T_{KN} = rated torque of coupling (Nm)

T_{AS} = peak torque of motor (Nm)

According to Acceleration Torque

For a more precise calculation the acceleration torque and respective moments of inertia of the driving shaft and the load are taken into consideration.

In the case of servo driven systems a safety factor should be applied, depending on the dynamics of the application. This factor is later reduced, depending on the inertia mismatch.

S_A = Shock or load factor

$S_A = 1$ (uniform load)

$S_A = 2$ (varying load conditions)

$S_A = 3-4$ (aggressive acceleration and deceleration cycles)

As a general guideline, S_A values of 2-3 are common for machine tool applications.

$$T_{KN} \geq T_{AS} \cdot S_A \cdot \frac{J_L}{J_A + J_L} \quad (\text{Nm})$$

T_{KN} = rated torque of coupling (Nm)

T_{AS} = maximum acceleration torque transmitted by the driving shaft (Nm)

- or maximum deceleration torque calculated for the load (Nm)

J_L = load inertia (kgm²)

J_A = driving inertia (kgm²)

According to Resonant Frequency

For the mechanical substitution model of the two mass system, the following calculation is used:

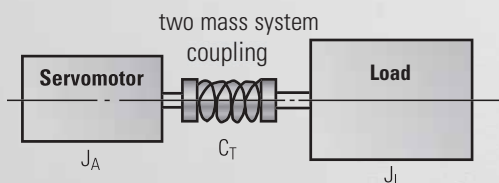

For practical application the following is used: $f_e \geq 2 \times f_{er}$

$$f_e = \frac{1}{2 \cdot \pi} \sqrt{C_T \cdot \frac{J_A + J_L}{J_A \cdot J_L}} \quad (\text{Hz})$$

C_T = torsional stiffness of the coupling (Nm/rad)

f_e = mechanical resonant frequency of the two mass system (Hz)

f_{er} = oscillation frequency of the driving shaft (Hz)

According to Torsional Stiffness

Transmission error due to torsional loading:

$$\varphi = \frac{180}{\pi} \cdot \frac{T_{AS}}{C_T} \quad (\text{degrees})$$

φ = torsional deflection (degrees)

C_T = torsional stiffness of coupling (Nm/rad)

T_{AS} = torque (Nm)

**Experience and
 knowledge for
 your special
 requirements.**

R+W Antriebs Elemente GmbH
 Alexander-Wiegand-Straße 8
 D-63911 Klingenberg/Germany

Tel. +49-(0)9372 – 9864-0
 Fax +49-(0)9372 – 9864-20

info@rw-kupplungen.de
 www.rwcouplings.com



TGA-ZM-05-91-00
 Registration No. 40503432/2

The information mentioned in this document is based on our present knowledge and experiences and does not exclude the manufacturer's own substantial testing of the equipment. So this is no obligatory assurance even with regard to protection rights of Third Parties. The sale of our products is subject to our General Conditions of Sale and Delivery.

THE R+W-PRODUCT RANGE



TORQUE LIMITERS
Series SK + ST

From 0.1 – 165,000 Nm, Bore diameters 3 – 290 mm
 Available as a single position, multi-position, load holding, or full disengagement version
 Single piece or press-fit design



BELLOWS COUPLINGS
Series BK + BX

From 2 – 100,000 Nm
 Bore diameters 3 – 280 mm
 Single piece or press-fit design



LINE SHAFTS
Series ZA + ZAE + EZ2 + EZV

From 5 – 25,000 Nm
 Bore diameters 5 – 140 mm
 Available up to 6 mtr. length



MINIATURE BELLOWS COUPLINGS
Series MK

From 0.05 – 10 Nm
 Bore diameters 1 – 28 mm
 Single piece or press-fit design



SERVOMAX®
ELASTOMER COUPLINGS
Series EK

From 2 – 25,000 Nm, Shaft diameters 3 – 170 mm
 backlash-free, press-fit design



ECOLIGHT®
ELASTOMER COUPLINGS
Series TX 1

From 2 – 810 Nm
 Shaft diameters 3 – 45 mm



LINEAR COUPLINGS
Series LK

From 70 – 2,000 N
 Thread M5 – M16



POLYAMIDE COUPLINGS
MICROFLEX
Series FK 1

Rated torque 1 Ncm
 Bore diameters 1.5 – 2 mm